

RightXpress

RCB-122B COM Express Type 2 Carrier Board

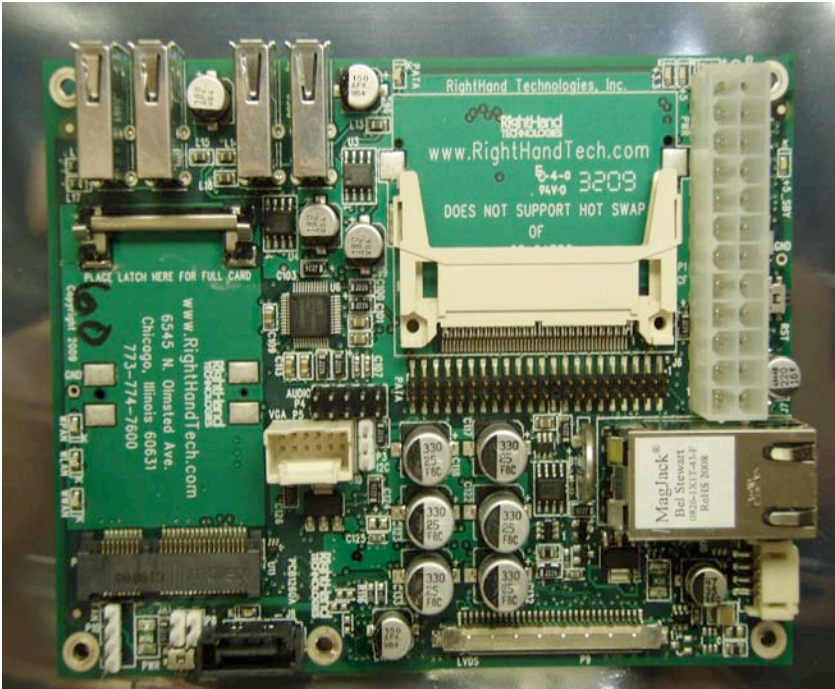

Reduce lifecycle costs, accelerate time-to-market and quickly respond to your customers' needs with the **RightXpress® RCB-122B**.

This ready-to-use carrier board hosts a commercial-off-the-shelf (COTS) COM Express module. The industry standard form factor matches the PICMG Type II standard. Its plug-and-play, customizable architecture is compatible with a variety of modules — allowing you to achieve optimum performance for your specific application.

The RCB-122B serves as both a development platform and reference design for developing your custom I/O subsystem.

RightXpress® RCB-122B Features

COM Express Interface

- 440 pin interface to integrated CPU, memory and I/O on a module
- Type 2 interface definition
- PICMG standard

Battery backed RTC

- 3V primary lithium battery

Fan Interface

- 12V connector
- Fused

Video Outputs

- 1 LVDS output
 - Option 1 – Dual channel 666 data interface
 - Option 2 – Single channel 888 data interface
- PWM backlight control
- VGA header (12 pin, includes EDID pins)

Networking

- 10/100/1000 Mbps LAN

Port I/O

- 4 x USB 2.0 host ports

Sensors

- Carrier temperature sensor accessible via SMBus

Mass Storage

- Type 1 CompactFlash socket
- PATA interface - Standard 2mm dual row 44 pin header (IDE)
- SATA interface

Non Volatile Memory

- Carrier EEPROM accessible via COM Express I2C bus

Audio Interface

- HDA codec (stereo)
- Line level input / output
- Headphone output

Mini PCI Express Socket

- Includes USB definition
- Build option for ½ size socket

Power Supply Interface

- 24 pin ATX Supply Input (+12V, +5V, +3.3V, +5V SBY)
- LED power indicator LEDs

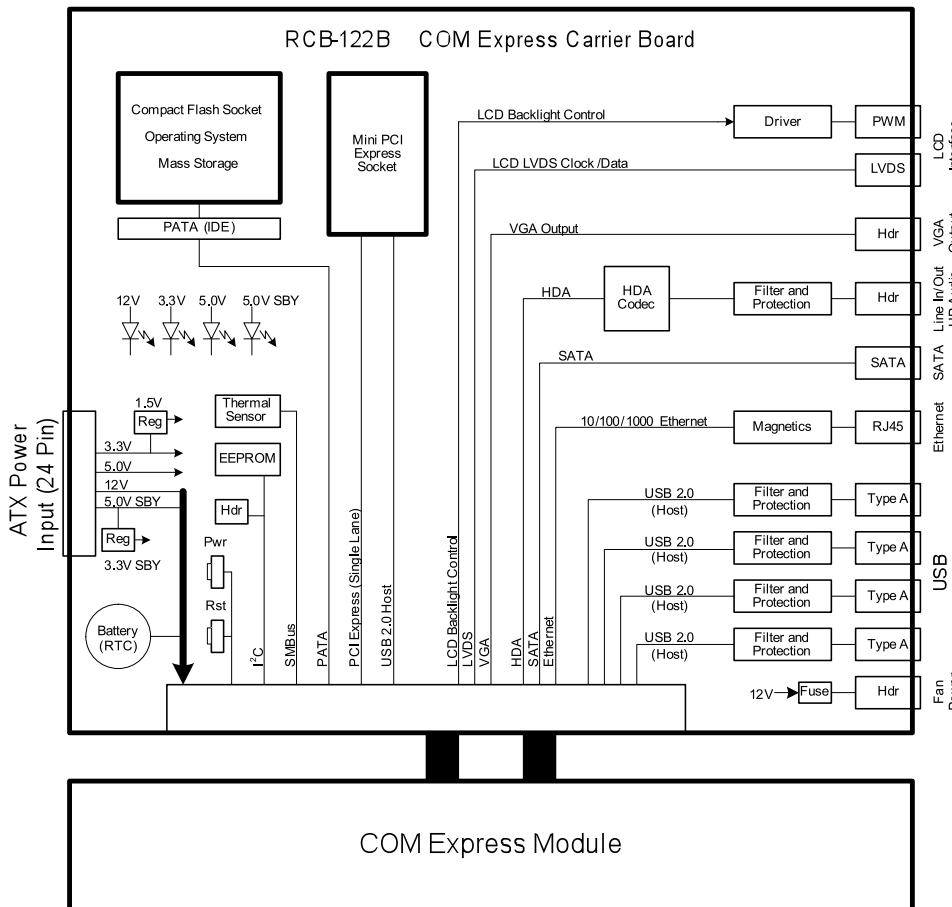

Suitable for Demanding Applications

The RightXpress® RCB-122B meets exacting quality standards, making it the right prototyping choice for:

- Aerospace
- Defense
- Industrial automation
- Gaming
- Medical equipment
- Embedded computing

Easy to Upgrade

Staying competitive through design upgrades is easier with the RightXpress® RCB-122B. Your design can migrate to the latest embedded processor roadmap using the same carrier board architecture — reducing time and development costs.

RightHand Technologies also can customize your carrier board architecture while utilizing the same COM Express solution.

Why Choose RightHand Technologies as your Carrier Board Provider?

- Access complete solutions, including hardware, software, mechanical engineering and manufacturing.
- Enjoy the flexibility to purchase boards in volume for manufacturing, or in smaller quantities for prototype development.
- Benefit from our engineers' extensive experience in embedded applications.

About RightHand Technologies

RightHand Technologies provides expert engineering design services and specialized manufacturing with sophisticated, full-validation functional testing for embedded electronic systems.

Whether you need a simple motherboard or a complex, high-speed design with challenging technical constraints, RightHand Technologies' experienced engineers will produce a high-quality design from your idea with timely delivery.

Ordering Information

Part No.	Description
RCB-122B	COM Express Carrier Board

Also Available: Custom Boards

Our design experts have developed dozens of custom carrier boards for a variety of markets and applications. Let us customize a board for your specific application.

For more information, contact:
Alan Germain
 (773) 774-7600, ext. 123
 agerman@righthandtech.com